

Pressure relief valves type REM

two stage, flange mounting SAE 3/4", 1", 1 1/4"

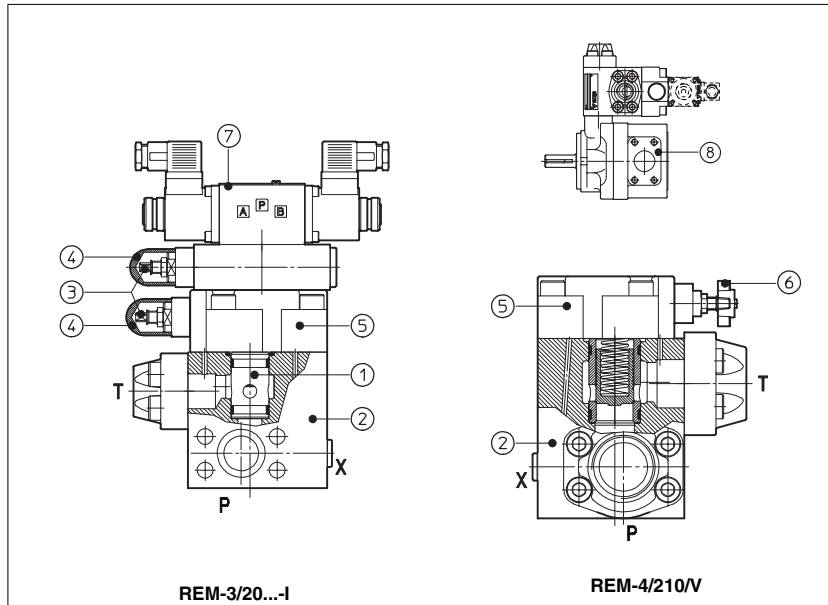

REM are double stage pressure relief valves with balanced poppet and SAE flange connection, designed to operate in oil hydraulic systems.

They can be direct by mounted with SAE flange attachments on the pumps outlet ports ⑧ and, in particular, on the PFE pumps (see tab. A005, A007).

In standard versions the piloting pressure of the poppet ① of the main stage ② is regulated by means of a grub screw ③ protected by cap ④ in the cover ⑤. Optional versions with setting adjustment by handwheel ⑥ instead of the grub screw are available on request. Clockwise rotation increases the pressure.

REM can be equipped with a venting solenoid valve ⑦ (for normally open or normally closed valves).

Mounting surface: SAE flange connection: 3/4", 1", 1 1/4"
 Max flow: 200, 400 and 600 l/min respectively.
 Pressure up to 350 bar (depending on models).

1 MODEL CODE

REM	- 4 / 2	0	/210 /100/100	/V	-I	X	24DC	**	/*
REM = pressure relief valve SAE flange mounting	(1)	(1)	(1)		(1)	(1)	(1)		Synthetic fluids: WG = water-glycol PE = phosphate ester
Size: 3 = SAE 3/4" 4 = SAE 1" 5 = SAE 1 1/4"									Design number
Number of the different setting pressure values: 1 = one setting pressure 2 = two setting pressure 3 = three setting pressure									Supply voltage, see section 7: 00 = solenoid valve without coils (only for OI solenoid)
0 = venting with de-energized solenoid 1 = venting with energized solenoid 2 = without venting									X = without connector See section 6 for available connectors, to be ordered separately
Pressure range: 50 = 4-50 bar; 100 = 6-100 bar; 210 = 7-210 bar; 350 = 8-350 bar (only for REM-3)									Solenoid of pilot valve: -I = solenoid OI (DHI) for AC and DC supply
									Options (2): /V = regulating by handwheel instead of a grub screw protected by cap
									Pressure range of second/third setting: 50 = 4-50 bar; 100 = 6-100 bar; 210 = 7-210 bar; 350 = 8-350 bar (only for REM-3)

(1) Only for REM with solenoid valve for venting and/or for the selection of the setting pressure

(2) For handwheel features, see technical table K150

2 HYDRAULIC CHARACTERISTICS

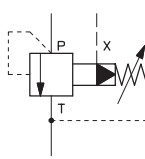
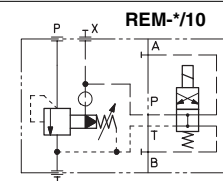
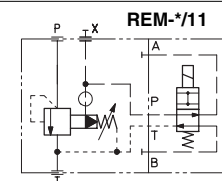
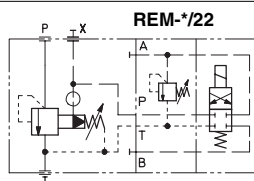
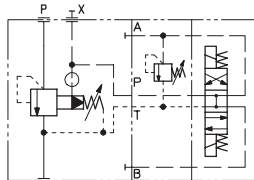
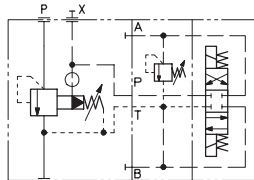
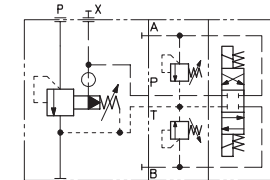
			
			
Valve model	REM-3		REM-4
Max flow [l/min]	200		400
Pressure range [bar]	4-50; 6-100; 7-210; 8-350		4-50; 6-100; 7-210

3 MAIN CHARACTERISTICS OF PRESSURE RELIEF VALVES TYPE REM

Assembly position	These valves can be installed in any position on the outlet port P of pumps with SAE flange attachments and in particular on PFE vane pumps
Subplate surface finishing	Roughness index $\sqrt{0.4}$, flatness ratio 0,01/100 (ISO 1101)
Ambient temperature	-20°C to + 70°C
Fluid	Hydraulic oil as per DIN 51524 . . . 535; for other fluids see section 11
Recommended viscosity	15 ÷ 100 mm ² /s at 40°C (ISO VG 15 ÷ 100)
Fluid contamination class	ISO 19/16, achieved with in line filters at 25 µm value and $\beta_{25} \geq 75$ (recommended)
Fluid temperature	-20°C +60°C (standard and /WG seals) -20°C +80°C (IPE seals)

3.1 Coils characteristics

Insulation class	H
Connector protection degree	IP 65
Relative duty factor	100%
Supply voltage and frequency	See electric feature 7
Supply voltage tolerance	± 10%

4 REGULATED PRESSURE VERSUS FLOW DIAGRAMS based on fluid viscosity of 25 mm²/s at 40°

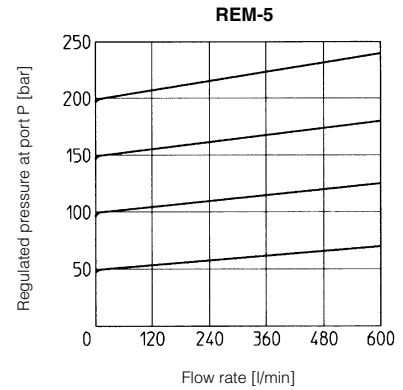
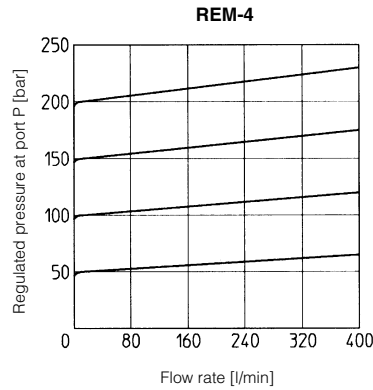
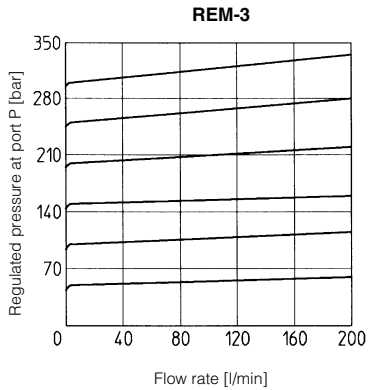

5 MINIMUM PRESSURE VERSUS FLOW DIAGRAMS based on fluid viscosity of 25 mm²/s at 40° C

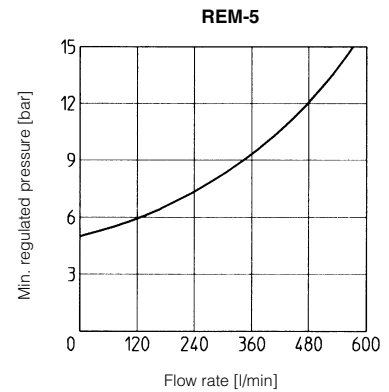
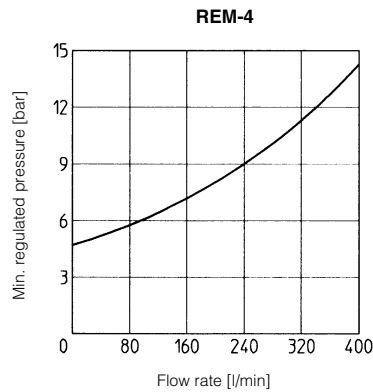
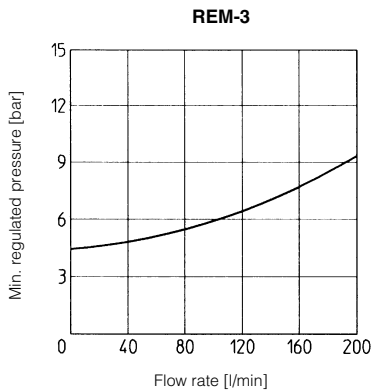

6 ELECTRIC CONNECTORS ACCORDING TO DIN 43650 FOR REM WITH SOLENOID VALVE

The connectors must be ordered separately

Code of connector	Function
SP-666	Connector IP-65, suitable for direct connection to electric supply source
SP-667	As SP-666 connector IP-65 but with built-in signal led, suitable for direct connection to electric supply source

For other available connectors, see tab. E010 and K500.

7 ELECTRIC FEATURES FOR REM WITH SOLENOID VALVE

Type of solenoid	External supply nominal voltage ± 10% (1)		Type of connector	Power consumption (3)	Code of spare coil	Colour of coil label
OI	DIRECT CURRENT	6 DC 12 DC 24 DC 48 DC	SP-666 or SP-667	33 W	SP-COU-6DC /80 SP-COU-12DC /80 SP-COU-24DC /80 SP-COU-48DC /80	brown green red silver
		ALTERNATE CURRENT	110/50 AC (2) 120/60 AC 230/50 AC (2) 230/60 AC	SP-666 or SP-667	60 VA (4)	SP-COI-110/50/60AC /80 SP-COI-120/60AC /80 SP-COI-230/50/60AC /80 SP-COI-230/60AC /80

- (1) For other supply voltages available on request see technical table E010.
- (2) Coil can be supplied also with 60 Hz of voltage frequency: in this case the performances are reduced by 10 ÷ 15% and the power consumption is 55 VA.
- (3) Average values based on tests performed at nominal hydraulic condition and ambient/coil temperature of 20°C.
- (4) When solenoid is energized, the inrush current is approx 3 times the holding current. Inrush current values correspond to a power consumption of about 150 VA.

8 DIMENSIONS [mm]

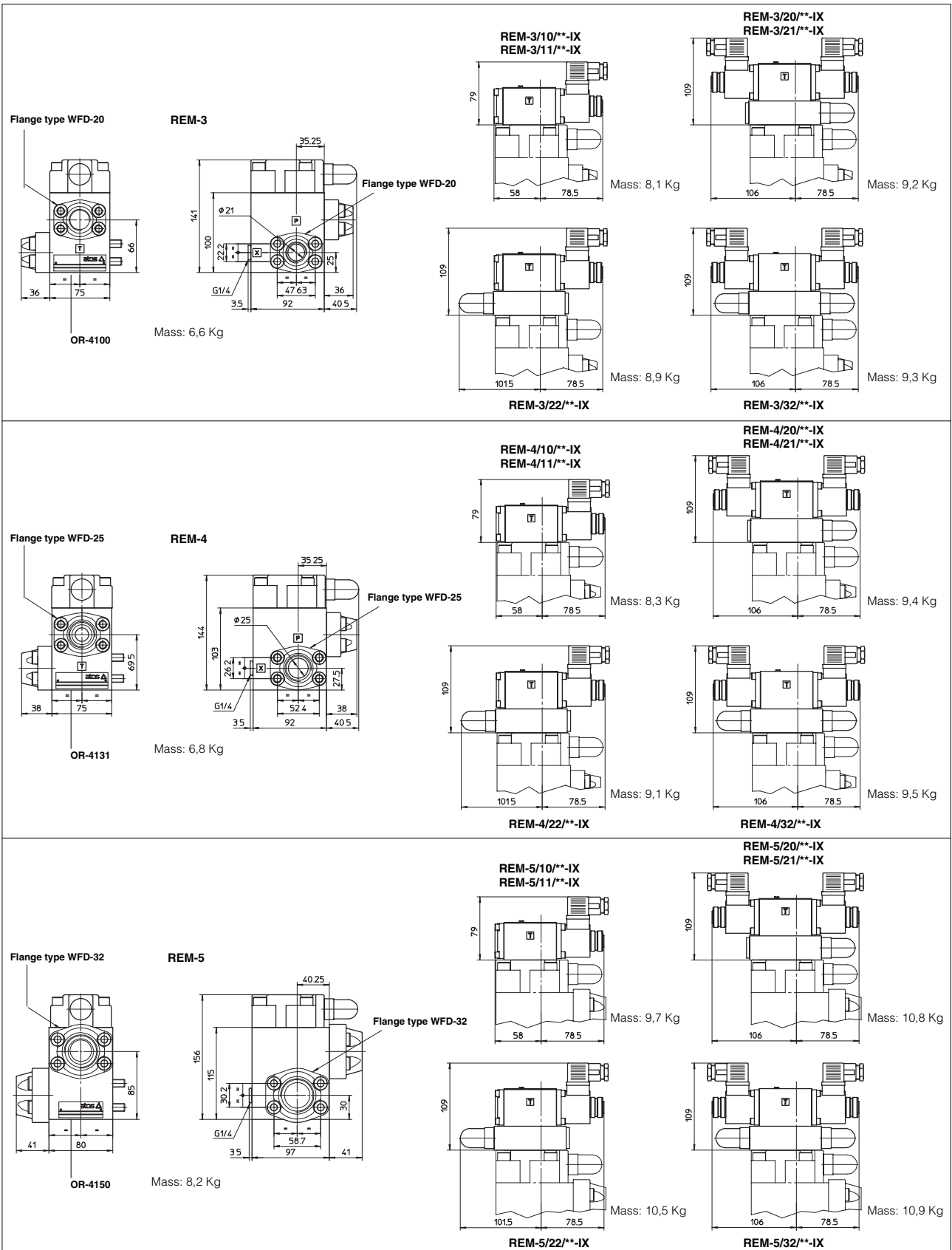

For dimensions of flanges, see tab. K120. Overall dimensions refer to valves with connectors type SP-666.

9 ASSEMBLY EXAMPLE OF A REM VALVE ON A PFE PUMP

